



Manufacturers of High Temperature & High Vacuum Equipment

1017 Bransten Road | Phone (650) 593-1064
 San Carlos, CA 94070 | Fax (650) 593-4458



Specification Sheet

Equipment Model: **J-Vac-12-18x48**
 High Vacuum Heat Treating / Brazing Furnace

| | |
|----------------------------|---|
| Type | Vertical Bell, High Vacuum |
| Chamber | Stainless Steel Coldwall with Internal Heating Elements |
| Maximum Temperature | 1250° C. (2300° F) |
| Hot Zone | 18" (450 mm) Dia. x 48" (1220 mm) H. Nominal |
| Frame Dimension | 76" (193 cm) W. x 36" (91 cm) D. x 145" (360 cm) H. |
| Vacuum pumps | Agilent 2000Lpm turbomolecular, with DS602 foreline |
| Power Requirements | 480V 3 Ph. 120A 60 Hz – 240V 3 Ph. 240A 60 Hz. |
| | 380/400/415V 3 Ph. 140A 50 Hz. |
| Gas Requirements | 25 – 50 psig, regulated, clean dry Nitrogen |
| | 25 – 50 psig, regulated, clean dry Argon |
| Compressed Air | 80 PSI regulated, Clean/Dry |
| Thermocouple | Type "C" Tungsten – Rhenium // Control & Monitor |

10⁻⁷ torr at room temperature
 10⁻⁶ torr at temperature
 Partial Pressure Argon operation included.

Cooling Requirements - 35 psig, at 10 gallons per minute.
 Note: Maximum backpressure is 15 psig. (125,000 BTU load at max temp)

Heat up ramp rate 70° C per minute - empty chamber.
 All Molybdenum Hot Zone & Elements. All Insulators are made of High Alumina.
 Element style - 1/8" Molybdenum Wire.

Standard Features:

- 2000 LP/S Turbomolecular Pump
- 600 L/min Mechanical "Roughing" Pump
- Easy to Operate Microprocessor Controllers
- 19 Programs - 20 Segments per Program
- Digital Chart Recorder
- Ethernet Connectivity, FTP and Webserver
- Independent Dual Heating Zones
- Active Braze Control
- **Turnkey Solution** - One button push starts the run. Automatically it will:
 - Rough pump
 - Cross over to high vacuum
 - Ramp to temperature
 - Process soak
 - Cooldown
 - Safely stop turbo and let up to atmosphere
 - Amber indicator light when run is finished and safe to open.

Options:

- Dry Scroll Pump
- Survey Thermocouples (up to 8)
- Computer Controls
- Combination Hydrogen/Inert Operation
- Residual Gas Analyzer (RGA)
- Tower Indicator Lights - 3 Color



Manufacturers of High Temperature & High Vacuum Equipment

1017 Bransten Road
San Carlos, CA 94070

Phone (650) 593-1064
Fax (650) 593-4458

Equipment Description:
Model J-VAC-12-18x48

CAMCo 18”(45cm) Dia. x 48”(120cm) H., 1250° C

TURBO-PUMPED, HIGH VACUUM FURNACE

For Automatic, Programmed Operation to 1250° C



Overview

This is Camco's second largest Furnace hot zone available to our customers in the coldwall style chamber. The model J-VAC-12-18x48 offers a hot zone at 18”(45cm) diameter by 48”(120cm) high. It has a bell type chamber assembly that is raised off the bottom chamber assembly to expose an 18”(45cm) diameter hearth plate that is located at a convenient height to load and unload parts of up to four feet (120cm) in height. It is dual zone controlled for temperature uniformity. The furnace and vacuum controls, pump system and interlocks are integrated in a fully automated computer controlled unit to assure simple, reliable operation. It is designed to operate at temperatures up to 1250° C (2350 F) at 10⁻⁶ torr vacuum. The furnace is fully automatic requiring the operator only to load the parts, select the desired recipe for processes, lower the chamber and press start. The furnace will automatically rough the chamber - cross over to high vacuum - ramp & soak to the pre-programmed temperature - cool down at a controlled rate and vent to atmosphere with nitrogen. In the atmosphere mode it is designed to operate in Hydrogen/Nitrogen mixed atmosphere and has the ability to divert a portion or all the process gas through a water filled bubbler to humidify the gas for processes requiring a reducing atmosphere. With the computer controlled option it will also operate in a partial pressure atmosphere.

Base Unit

The base unit measures 76”(193cm) wide by 34”(86cm) deep by 40”(100cm) high. Its' substantial frame is constructed of heavy wall square steel tubing. With the chamber fully raised the hoist and chamber assembly is 12’(365cm) high. Service access is readily gained through a hinged steel door and the removable front, side and rear panels. The plate steel floor within the base unit supports the heating transformer and closes the bottom. Also contained within the base are the SCR units, power components, and other electronics. At the lower right are the atmosphere control module, gas plumbing and cooling water plumbing. The high vacuum turbo pump, roughing pump and manifolding are also located within the right side of the cabinet. In addition, the base frame supports the instrument console and the water-cooled chamber bottom end at a convenient operator height for loading of product. A fan at the rear of the base unit draws cooling air through a replaceable filter element to cool the power control unit and transformer. A handy feature is the inclusion of recessed heavy-duty casters. The unit is easily rolled into place, and the leveling feet lowered to immobilize and level the equipment. With the removal of the hoist assembly and the top cover this unit can fit through a standard door. The finish used on this, and all CAMCo equipment is baked powder coating, chosen for its' durability. The stainless steel top skin reduces the possibility of load contamination.

Hoist Assembly

The chamber/furnace assembly is mounted to the arm of the motor driven hoist assembly by which it may be raised to provide access to the work area. The mounting allows the chamber to lift with respect to the hoist. The hoist itself is screw driven, and cannot inadvertently lower on the removal of power. Its speed is approximately eighteen inches per minute, a rate that is slow enough to minimize jarring, while not being inconvenient. Limit switches control the extremes of travel. Large bearing areas assure hoist rigidity and long life, and further assist in providing close registration of the chamber to the chamber bottom assembly upon closing.

Temperature Control

Temperature control and monitoring functions to 1250° C. are achieved using type “K” Chromel vs. Alumel thermocouples. The control thermocouple, in close proximity to the element zone, ensures long furnace life by controlling the element temperatures to safe values regardless of load thermal mass. Multi-stage programmed control is achieved through use of the computer controlled I/O unit which compares the setpoints with the inputs from thermocouples located in close proximity to the heating elements, sending an appropriate drive signal to the SCR power controllers. Totally automatic time/temperature programmed control of up to ten different, 14 segment programs may be stored. Over temperature monitoring is provided by a second thermocouple located within close proximity to the load. It drives an internal Watlow OT control set to 1250° C in case of runaway temperature. This signal is also monitored in the computer software which provides for an additional overtemp setpoint which can be set lower for each individual program recipe. A thermocouple feedthrough at the bottom of the chamber, and related holes in the shields, allow survey thermocouples to be inserted to monitor actual temperature of load. These thermocouples can be used in conjunction with the “Active Closed Loop Braze Control”.

Active Closed Loop Braze Control

The Furnace comes standard with one type “K” Inconel sheathed survey thermocouple that can be attached to the workload. This thermocouple drives a second channel on the program controller that can be integrated with the process control. These thermocouples are rated for use up to 1250° C (2250° F).

Operation

The work is loaded onto the 18” (45cm) diameter hearth plate and the chamber is lowered via the hoist switch. One of ten selectable, user programmed thermal profiles is chosen, and the “Run” key pressed. A one-button push will start the run and automatically it will rough the chamber, cross over to the high vacuum pump, ramp to temperature and soak, cool-down and vent with nitrogen. Upon completion of the cooldown portion of the program, the chamber is opened and unloaded. For atmosphere operation a one button push will start the run and automatically it will vacuum purge and run a rate of rise test, process gas fill, ramp to temperature and soak, activate the bubbler for humidification of process gas, cooldown and post purge. Upon completion of the cool down portion of the program, the chamber is opened and unloaded.

Chamber/Furnace assembly

The stainless steel water-jacketed chamber bottom end is mounted on the base unit. It is sealed to the chamber by a flange containing a viton “O” ring. Four high pressure pneumatic clamps are used to keep the chamber sealed from atmosphere. The location of the seal is such that it is well cooled and optically baffled assuring long life. The chamber bottom includes work and survey thermocouple feed-throughs, gas admission and vacuum gauges. It supports the Molybdenum hearth and bottom end stack of six shields via the lower support structure. The furnace hot zone is located within the jacketed stainless steel chamber. It incorporates two sets of Molybdenum heating element consisting of six sections each supported by high alumina insulators. This surrounds the 18” diameter by 48” high work area. A series of four Molybdenum cylindrical heat shields and the top and bottom stack of four shields surround the elements. This assembly is supported from the inner wall of the chamber.

In addition, the chamber includes 12 insulated water-cooled power feedthroughs, 2 control thermocouples, 2 sightports, and required cylindrical heat shield support structure. Perforated stainless steel guards surround the heater power feedthroughs and provide electrical protection to the operator. The chamber assembly is supported by the hoist arm, and is located by pilot guides to assure accurate registration to the chamber bottom assembly when the furnace is lowered. Pneumatic clamping assures a positive seal to the bottom chamber assembly.

Power Control

Power is proportionally controlled through use of two digitally controlled SCR three phase power module. These units are phase angle fired control, and includes three phase current limiting made necessary by the strongly positive resistivity coefficient of the heating element. Impedance match of the heating elements to the incoming power is accomplished through a conservatively rated 40 KVA transformer driven by this power module.

Vacuum System

This automatically controlled, turbo pumped version of the type J Furnace is designed for clean, oil-free elevated temperature in a high vacuum atmosphere. From a cold start, the clean furnace will evacuate to the 10^{-6} Torr range in approximately 20 minutes, and is capable of maintaining six-scale vacuum at temperature. When pumped for a longer period, lower pressures are easily attained. The vacuum plumbing is designed to provide convenient component access, and to provide maximum practical conductance to the chamber. Mass spectrometer leak checks are performed on all high vacuum assemblies. A ten inch ISO 250 water-cooled elbow is used to baffle the turbo-pump, gate-valve and vacuum gauging during heating to ensure long pump life. The high vacuum system is specifically designed to handle the large gas loads presented by vacuum furnaces. An ISO250 flanged, 2000 L/Sec. ceramic bearing turbo molecular pump, capable of 10^{-9} scale ultimate vacuum, is used for the application. The turbo-pump is capable of very rapid 3 thru 7 scale pumping of air and water vapor typically evolved during the earlier out-gassing part of the firing cycle. For maximum pumping speed, it is close coupled to the chamber pumping elbow through the high conductance high vacuum gate valve. Chamber roughing is accomplished through the turbo pump by a quiet, direct drive mechanical pump. At acceptable foreline pressure, the turbo-pump is automatically powered up. For ultra clean operations, a dry scroll or diaphragm pump can be substituted for the mechanical pump. The foreline includes a baked molecular sieve back-streaming trap and electro-pneumatic foreline valve. The ion gauge is turned on and a 1 min gauge degas is performed every run.

Vacuum Instrumentation and Control

Individual modular Granville-Phillips digital gauge control units, two Convectron (Pirani) gauges and one Bayard-Alpert Ion gauge, are used to monitor system pressure. A self-cleaning degas feature helps keep the Ion gauge calibrated and the process consistent. The Bayard-Alpert Ion gauge tube, and the Convectron that measures chamber pressure are located on the ISO250 flanged chamber neck. The second Convectron is located in the foreline to measure pressure at the roughing/backing line. All pressures are monitored at the computer and displayed to the operator.

Vacuum ramp delay

A circuit receiving a signal from an ion gauge related set-point can be used to toggle the program controller between run and hold to keep below a programmed vacuum cap during periods of high gas load (vacuum/heat ramp delay). This can be the key process that helps maintain an oxide free atmosphere. Linearized, analog output provided by the gauge control may be coupled to a recorder when a recorder is ordered.

Atmosphere Control Option

The model JVAC-1200 [18x48] can be ordered with combination hydrogen atmosphere control. Customer supplied Hydrogen and Nitrogen gasses are admitted to the chamber through programmed valves and preset flow-meters. An interlock is included which provides for automatic Nitrogen purge in the event of loss of Hydrogen/Nitrogen or chamber pressure. Operator set flow-meters control the flow of gasses to achieve the appropriate operating atmosphere. Included is a system which, when called to do so by the installed program, humidifies a portion of the selected process gas via a bubbler column. This gas is then recombined with the remaining process gas in a pre-selected ratio to obtain the desired process dewpoint (in °C). The included bubbler column will humidify the process gas to a dewpoint of up to 25° C. Higher dewpoint equipment, and controlled temperature bubblers are available.

Exhaust gas is routed through a check valve in the exhaust line from the top of the chamber. This valve establishes a slight positive pressure when the chamber is sealed. As a safety feature, absence of this pressure prevents admission of Hydrogen and inhibits the application of heater power. An exhaust gas burn-off column electronically ignites the waste gas. Ignition is called for automatically at all times that Hydrogen is called for, and the unit attempts re-ignition should the flame be inadvertently extinguished. The igniter is automatically tested to assure proper operation each time a run is started. All gas plumbing and components are Stainless Steel. All gas connections are high quality high-pressure Swagelok fittings.

Safety Features

- Thermocouple break protection (Thermocouple burn-up) assures that heating power is removed from the furnace in the event of sensor failure.
- Over-temperature indication is monitored on a separate control module from the computer ensuring element shutdown in case of a run-away.
- Overtemp is programmed in each individual recipe and can be different from run to run

Other numerous interlock functions protecting the operator and equipment include:

- Panel Interlock
- High Cabinet Temperature
- Low Coolant Flow
- Low Gas Pressure Switches
- Vacuum Ramp Delay
- Heaters are interlocked with the vacuum gauge control so that heating will not occur if there is insufficient vacuum.
- Thermal overload protection for the Turbo Molecular Pump
- High Vacuum isolation valve to protect the Turbo Pump during vent and quick cooling of the hot zone.
- The Chamber is vacuum purged and a rate of rise is performed at the beginning of each run.
- All interlocks are software and hardware connected.

Digital Chart Recorder

Included in every Camco Furnace is a digital chart recorder for continuous monitoring of thermocouple inputs and other components. Standard inputs include control thermocouple, part thermocouple, over-temperature thermocouple, and program setpoint. Other inputs that can be monitored (based on options ordered) include additional survey thermocouples, dewpoint monitors, current sensors, vacuum transducers, coolant temperature and oxygen analyzers.

This chart recorder includes 512MB of memory which covers decades of recordings. It is packaged with convenient software for reading files and can be either read from an external memory card or connected to a network and read remotely via FTP.

The recorder also has webserver functionality that runs through the network to show you quickly the current state of the furnace in real time. This feature is especially useful if the furnace is to be installed, for example, in a clean room where access is limited (or a hinderance to physically get to).

Documentation

Facilities information is supplied to assist in site preparation for installation. An operating manual is supplied with the equipment. Worksheets included in the manual provide a convenient form to depict the desired process for entry into the microprocessor controller. The worksheets also serve as a hard copy of the program. The unit is shipped with an example program stored in memory, depicted by the example worksheet. Wiring and plumbing schematics along with a published spare parts list are also included in the manual. Vendor supplied manuals for the program controller, overtemp, SCR, recorder, dewpointer, and other small items are supplied in our documentation. A program and operation section has a complete button-by-button push instruction for installation of a generic program. Relatively simple operation of the furnace is well described and documented in the manual.

| REV. | DATE | DESCRIPTION |
|------|------|-------------|
| | | |
| | | |
| | | |

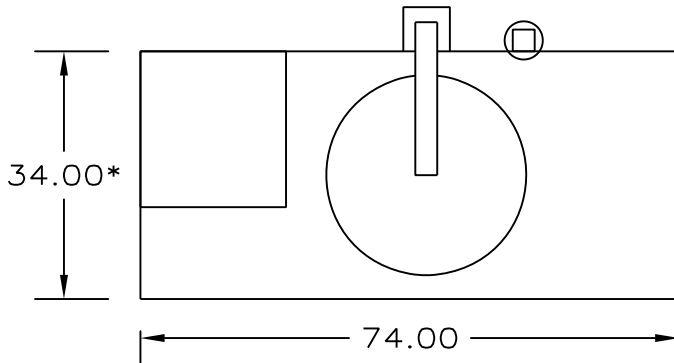

NOTES;
FRAME IS ON CASTORS
TO ROLL INTO POSITION

LEVELING GUIDES TO
SECURE POSITION

BURN-OFF SHOWN FOR
COMBINATION VAC ATM
MODELS

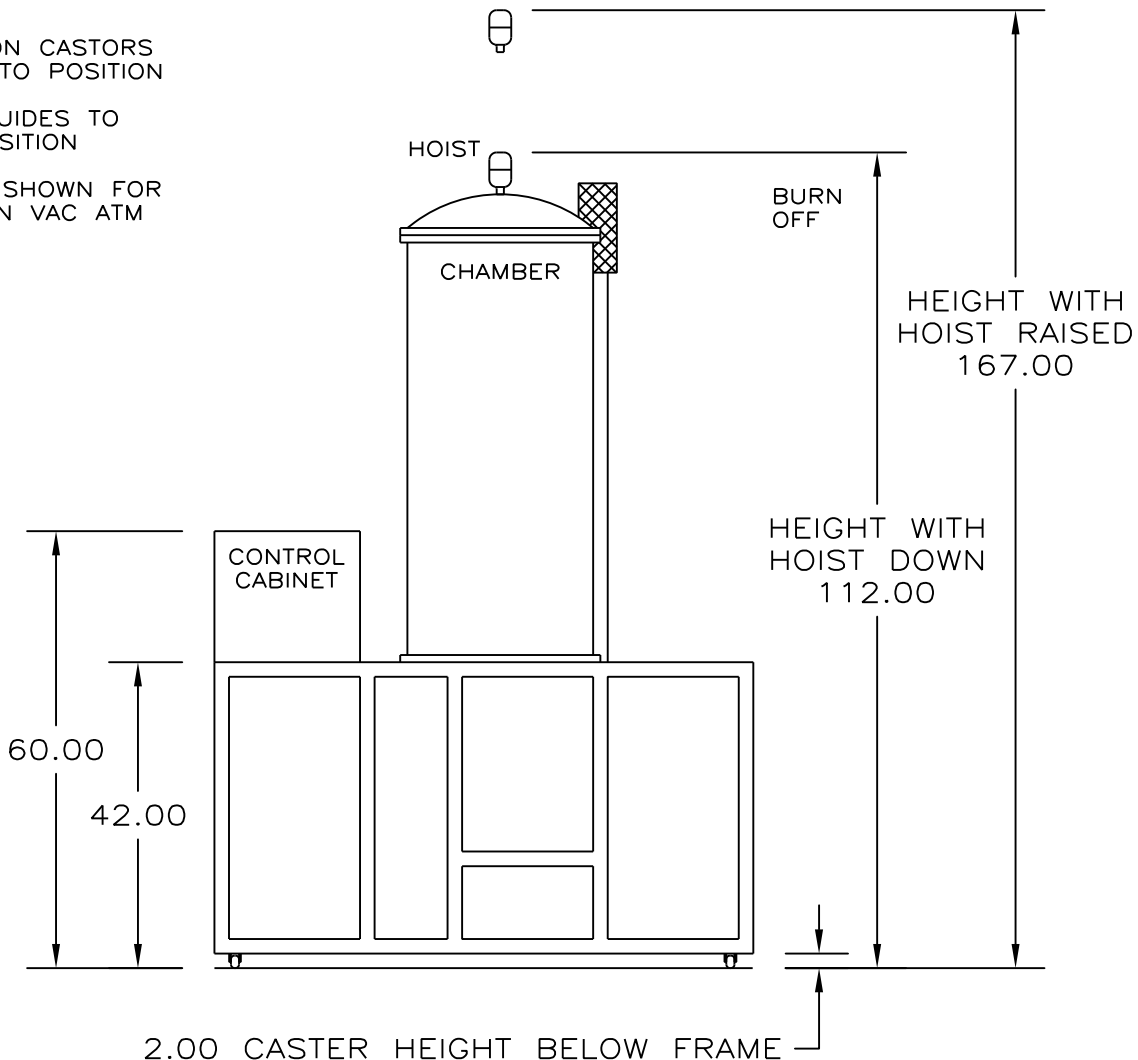

*WITH HOIST REMOVED.

NOTE: WITH THE TOP END OF THE CHAMBER AND THE HOIST REMOVED, THE FURNACE WILL FIT THRU A 3-0 DOOR.

NOTICE: This document contains information which may be confidential and/or tradeseecret and/or proprietary to Concepts & Methods Co. Inc. and its' affiliates. This document is submitted to you in confidence and shall not be reproduced, disclosed to others, or used in manufacture without the express written permission of Concepts & Methods Co. Inc.

| | | | | |
|--------------|-----|----------------------|--------------------|--|
| | | TOL'S EXCPT AS NOTED | DRN.BY: T BARULICH |  Concepts & Methods Company, Inc. |
| | | fract. ±1/32 | APP.BY: | |
| | | .XX ±.010 | DATE: 12-8-09 | |
| | | .XXX ±.005 | MAT: | |
| J-VAC 18X48 | 427 | .XXXX ±.0005 | FINISH: | TITLE: J-VAC 12 18X48 FRAME DIM |
| USED ON TASK | FWO | ANGLES ±1/2' | | DWG.NO: 89320 |
| | | | | SHEET OF |
| | | | | REV: |



DUAL ZONE HEATING
 18 X 50 HOT ZONE
 ALL MOLYBDENUM SHIELDS
 AND ELEMENTS

| REV. | DATE | DESCRIPTION |
|------|------|-------------|
| | | |
| | | |
| | | |

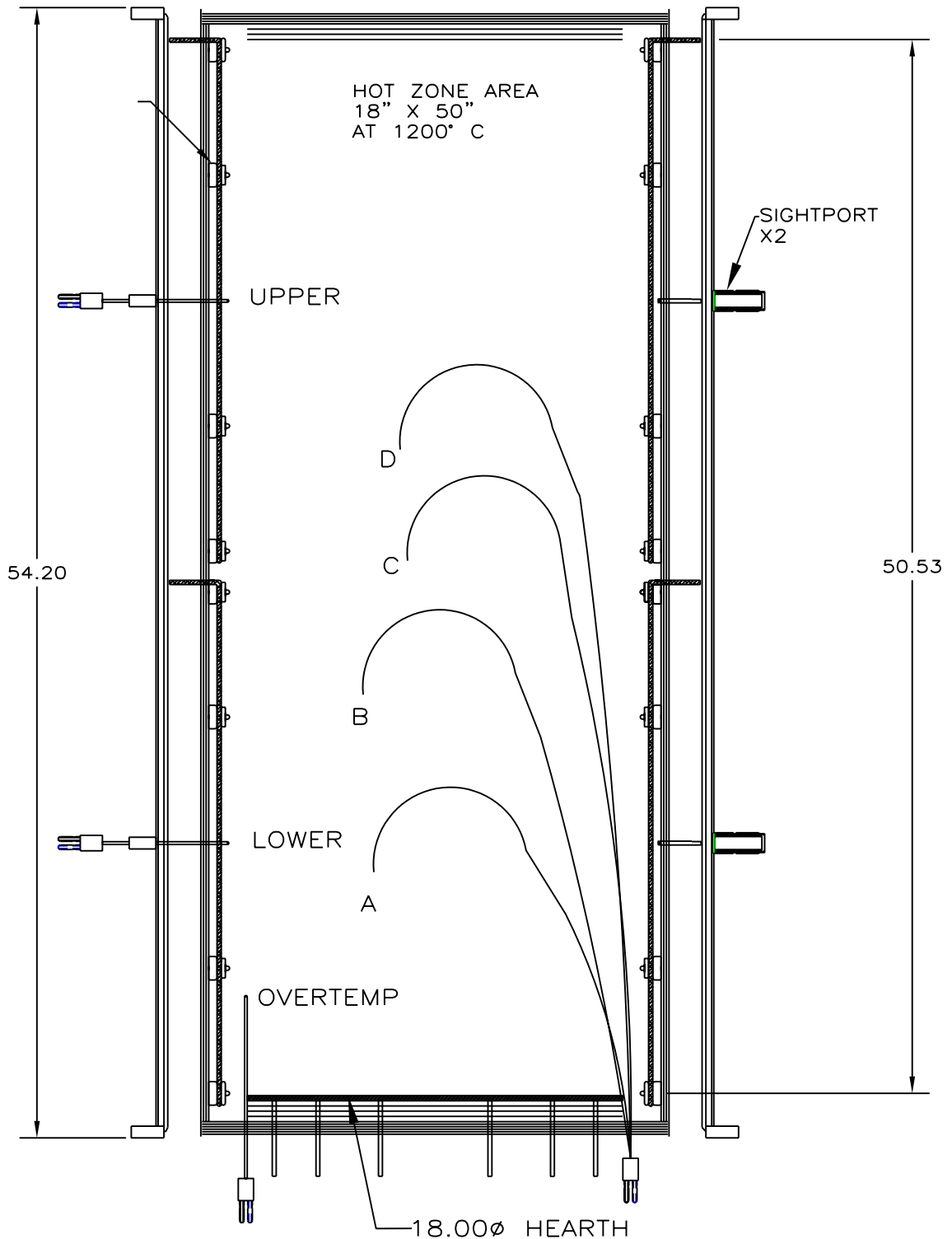

NOTICE: This document contains information which may be confidential and/or tradeseecret and/or proprietary to Concepts & Methods Co. Inc. and its' affiliates. This document is submitted to you in confidence and shall not be reproduced, disclosed to others, or used in manufacture without the express written permission of Concepts & Methods Co. Inc.

| | | | | | | | |
|--------------|-----|-------------------------|--------------------|---|---------------|----------|------|
| | | TOL'S EXCPT AS NOTED | DRN.BY: T BARULICH |  | | | |
| | | fract. ±1/32 | APP.BY: | | | | |
| | | .XX ±.010 | DATE: 8-29-05 | | | | |
| | | .XXX ±.005 | MAT: NOTED | | | | |
| J-VAC 18X48 | 318 | .XXXX ±.0005 | FINISH: | TITLE: J-12-18X48 HOT ZONE | DWG.NO: 88961 | SHEET OF | REV: |
| USED ON TASK | FWO | ANGLES ±1/2' | | | | | |